



2018 PRODUCT CATALOG

INDUSTRIAL PLUGS & RECEPTACLES

- SWITCH-RATED PLUGS & RECEPTACLES
- HAZARDOUS LOCATION PLUGS & RECEPTACLES
- CUSTOM POWER DISTRIBUTION PANELS
- HIGH AMPERAGE CONNECTORS
- MULTIPIN CONNECTORS



Introduction

MELTRIC Overview	pg 2
Product Features & Benefits	pg 4
Product Summary & Selection Guide	pg 8
Part Number & Ordering Guide	pg 14
Switch-Rated Plugs & Receptacles	
The Main Differences	pg 16
Selection Guide	pg 20
DSN Type 4X/IP69k rated, metal or poly casings. From 20 – 150A (1/2 – 75 hp)	pg 22
DS Type 3R rated, metal or poly casings. From 20 – 200A (3/4 – 100 hp)	pg 38
DB IP67 rated, metal casings. From 30 – 100A (2 – 60 hp)	pg 56

Multipin Plugs & Receptacles

Multipin 4 – 37 pin connectors in poly and metal. From 2 – 150A	pg 70
--	-------

Standard Duty Plugs & Receptacles

DR Type 3R rated, poly or metal casings. From 30 – 400A	pg 96
PN IP66/IP67 rated or IP54 rated, poly or metal. 20A	pg 114
High Temp For environments up to 465°F (240°C)	pg 122

Direct Current Plugs & Receptacles

DSDC DC current rated, poly or metal casings. Up to 750 VDC	pg 126
--	--------

High Ampacity Plugs & Receptacles

PF/PFQ IP66/IP67 rated, metal construction. From 300 – 600A	pg 132
DR400 Type 3R rated, metal casings. 400A	pg 140
SP Single pole, connectors up to 600A	pg 144
CS1000 Single pole, connectors up to 400A	pg 148

Power Distribution

Custom Power Distribution Solutions Built specifically to meet customer needs	pg 154
Integral Circuit Protection Wall Boxes Premounted receptacles wired to circuit protection 20-60A	pg 162
GFCI Combinations Premounted receptacles wired to GFCI boxes 20-60A	pg 168
Safety Switch/Receptacle Combinations Switch-rated receptacles mounted to single throw, fusible safety switch	pg 170

Specialty Products

WS – Welding Connectors Single pole connectors (max 50 VAC)	pg 174
Adapter Plates For converting existing receptacles to MELTRIC	pg 175
Cord Grips	pg 178
Voltage/Phase Rotation Meter Assemblies	pg 180

Hazardous Location Plugs & Receptacles

Hazardous Duty Selection Guide	pg 184
DXN Hazardous rated, poly casings. From 20 – 60A (1/4 – 20 hp)	pg 186
DXA Hazardous rated, metallic casings. From 20 – 100A	pg 198
DSN/DS/DR/DSDC Hazardous rated, metallic casings. 2 – 250A (up to 100 hp)	pg 202
DX Hazardous rated, metallic casings. From 20 – 125A	pg 226
Multipin Hazardous rated, 12 to 37 pins, 10A	pg 236
SPeX Hazardous rated, up to 680A, 1000VAC	pg 242

MELTRIC Corporation

The best in industrial wiring devices



At MELTRIC Corporation, our only business is electrical plugs and receptacles. We are focused on providing our customers with the best overall value by offering the safest, highest quality and most reliable plugs and receptacles, and by backing them with outstanding service and support.

Product Technology & Safety

The technology behind MELTRIC's products was developed specifically to address the shortcomings and safety hazards common with pin & sleeve type plugs and receptacles. In 1952, following the observation of an accident with a pin and sleeve device, Gilles Marechal devised the concept of combining the advantages of silver-nickel butt contacts and the load making and breaking capabilities of a switch with the convenience of a plug and receptacle. Shortly thereafter, the first of these products was born. MELTRIC licensed this technology in the early 1980's and has been supplying its products to North American customers ever since.

Value

With their unique features and capabilities, MELTRIC products provide users with a safer and more reliable product than competitive pin and sleeve devices. MELTRIC's butt-style contacts provide longer operating lives, optional integral pilot contacts reduce the need for additional connectors and our switch-rated plugs and receptacles can eliminate the need for auxiliary interlocks and disconnect switches, helping users reduce equipment costs. These advantages, together with competitive pricing, short lead times, and 5-year warranty on electrical contacts, make MELTRIC's products the best overall value in the plug & receptacle/connector market.

Service & Support

MELTRIC backs its superior products with outstanding service and support. A network of over 150 sales associates and over 2000 distributor locations throughout the US, Canada and Mexico make access to our product easy.

MELTRIC's Customer Service group is trained to answer most questions on the spot and is located at our manufacturing facility in order to help streamline the order fulfillment process. Our engineering team stands ready to provide both application support and custom designed products incorporating MELTRIC and third party components into power distribution products tailored to meet your needs. Friendly and personal assistance is only a toll free call away at (800) 433-7642.

Many of MELTRIC's products are designed in a modular fashion, which permits cost effective stocking of components and quick final assembly of the product. Together with efficient order handling by Customer Service, this helps MELTRIC to provide the shortest lead times in the industry.

Quality

Quality is not just an inspection function at MELTRIC. Quality starts with intelligent designs, robust materials, clear procedures, process measurement and controls and effective communications. It is completed by the care, commitment and involvement of each of our employees.

MELTRIC is dedicated to the continuous improvement of all its critical production and support processes and is ISO 9001:2015 certified. MELTRIC designs and manufactures its products to exceed the requirements of applicable UL, CSA and IEC standards.



Worldwide Availability

Marechal Technology products are manufactured in North America, Europe, South Africa and Australia. MELTRIC supplies product directly from its factory in Franklin, Wisconsin to customers in the United States, Canada and Mexico. For customers outside of North America, product is provided through other Marechal Electric Group companies and sales agents.

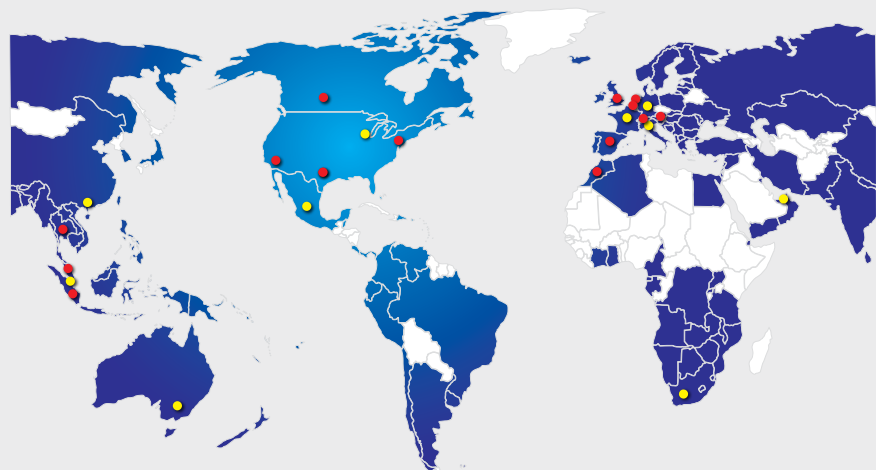

- SALES OFFICES & MANUFACTURING PLANTS
- COMPANY SALES PRESENCE
- SALES AGENTS & DISTRIBUTORS



MELTRIC PRODUCT FEATURES...



Spring-Loaded Butt Contacts

MELTRIC products feature spring-loaded, butt contacts similar to those used in contactors and switchgear. These contacts have numerous advantages, which help improve electrical performance and user safety relative to pin and sleeve contacts or the arcuate contacts used in twist-type devices.

Butt-style contacts ensure a very positive and consistent connection. The spring-loading of these contacts, which is accomplished with coil springs, provides a desirably high contact force that remains constant over thousands of operations. In addition, it automatically compensates for any wear and/or deviations in contact length resulting from manufacturing tolerances.

This is a critical point, as contact force is a key determinant of the quality of a contact. As the accompanying chart demonstrates, contact resistance increases as contact force is reduced. Higher contact resistance generates more heat

and oxidation, both of which contribute to the deterioration of the contact. This is a problem with pin and sleeve and arcuate type contacts because their contact force varies with manufacturing tolerances and is reduced due to wear that occurs with normal use.

Most MELTRIC contacts close with a self-cleaning wiping action. When the contacts initially mate, they are slightly offset. In completing the connection, the plug contacts are rotated across the receptacle contacts, helping to remove deposits from the contact surfaces.

In conjunction with the spring-loaded casings used on many MELTRIC products, the spring-loaded contacts ensure a quick breaking of the connection that is independent of the motion of the user. By contrast, the disconnection speed of pin and sleeve and twist-type devices is dependent upon the motion of the user.

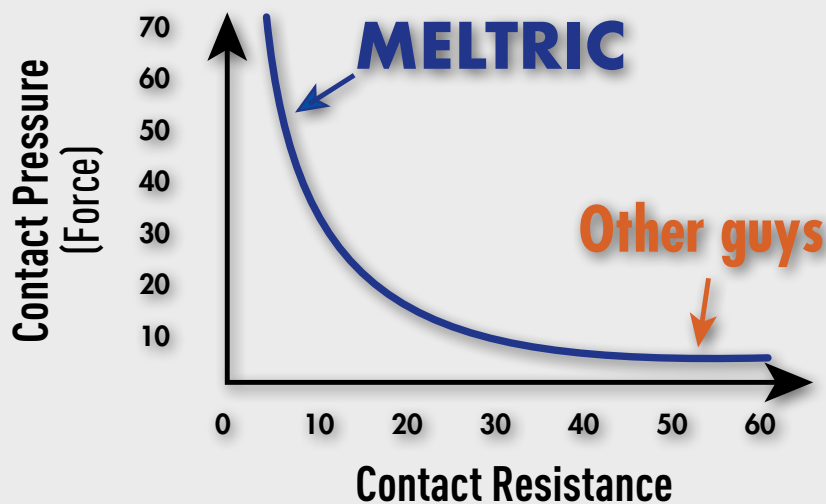

...AND BENEFITS

Silver-Nickel Contact Material

MELTRIC uses solid silver-nickel (85%/15%) contacts. The silver-nickel material has significant advantages over the brass contacts commonly used on competitive devices.

Silver has very low initial contact resistance and is not negatively affected by oxidation. This helps to give it excellent electrical properties that are maintained even at high temperatures and after tarnishing. Nickel is a much harder material and contributes excellent mechanical properties. The combination of silver and nickel results in a contact material that has both superior electrical capabilities and excellent resistance to wear. Silver-nickel only welds at extremely high pressure and temperature, and thus, also withstands arcs very well. These features make silver-nickel a commonly used contact material by switchgear manufacturers.

By contrast, the brass material used in most competitive plug and receptacles has much higher initial contact resistance and is negatively affected by oxidation. In an oxidized state, the contact resistance of brass is more than 20 times higher than that of silver-nickel. In addition, brass is a soft material that wears rapidly. In use, brass pin and sleeve and arcuate contacts suffer from the combined effects of the limitations of the material and the design. As oxidation and wear induced reductions in contact force occur, contact resistance increases. This increases operating temperature, which causes further oxidation and wear, perpetuating a vicious cycle of degradation. Brass is not arc resistant and is not suitable for making and breaking under load.

Dead Front Construction

Most MELTRIC products feature dead front construction, which greatly enhances safety by eliminating any unintended access to live parts. On most MELTRIC products, the dead front is accomplished with a safety shutter that can be opened only by an appropriate mating plug. The live receptacle contacts can only be accessed by the plug, after its insertion into the receptacle. The design of the product also ensures that the plug contacts are dead before the user can remove the plug from the receptacle.

By contrast, pin and sleeve and twist-type devices do not have a safety shutter. Access to live receptacle contacts is possible, and on some devices the plug contacts may be live and accessible when the plug is being removed.



MATERIAL	CONTACT	
	NEW	OXIDIZED
SILVER	6 $\mu\Omega$	25 $\mu\Omega$
SILVER-NICKEL	23 $\mu\Omega$	60 $\mu\Omega$
COPPER	29 $\mu\Omega$	400 $\mu\Omega$
BRASS	370 $\mu\Omega$	1400 $\mu\Omega$



MELTRIC PRODUCT FEATURES...

Push-Button Circuit Disconnection

To disconnect most MELTRIC products, the user simply needs to depress the pawl. This causes the circuit to be disconnected and the plug to be ejected to its rest (off) position in the receptacle. If desired, the user can then remove the plug from the receptacle by rotating it slightly and then withdrawing it. This mode of operation ensures that it is only possible to remove the plug after its contacts have been deenergized.



Enclosed Arc Chambers

The contacts on most MELTRIC products make and break within enclosed arc chambers. This ensures that the arcing which normally occurs during the making and breaking of the contacts is contained inside the device. This greatly enhances safety and avoids potential injury to users and/or harm to the outside environment.

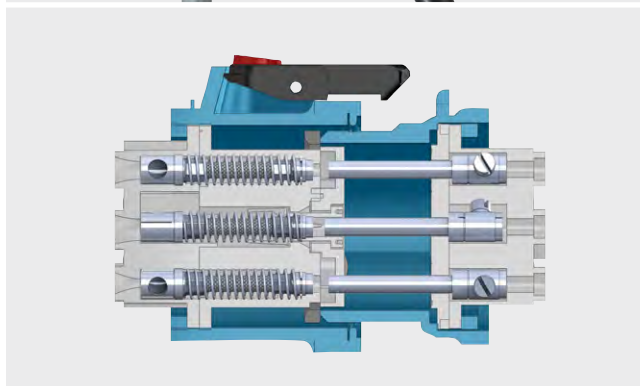

Optional Auxiliary/Pilot Contacts

Many MELTRIC products are available with optional auxiliary/pilot contacts. These integral pilot contacts allow users the convenience and flexibility of controlling auxiliary equipment, monitoring parameters (such as motor temperature), and/or communicating alarms through the same plug and receptacle used to supply power to the equipment. Because the pilot contacts are integral, they also facilitate the rapid change-out or reconfiguration of equipment by eliminating the need for hard wiring or multiple plug connections.

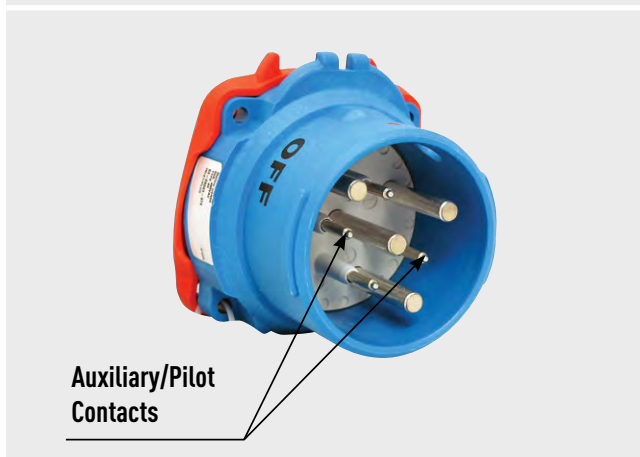

Automatic Watertightness

On most pin and sleeve devices, an additional plastic ring must be tightened in order to ensure the achievement of rated watertightness. Users frequently fail to do this, resulting in leakage. MELTRIC solves this problem with its DS and DSN Switch-Rated plugs and receptacles, which achieve their rated watertightness of up to Type 4X/IP69k simply by mating the plug with the receptacle. After the removal of the plug, rated watertightness is maintained for the receptacle by simply closing the lid.

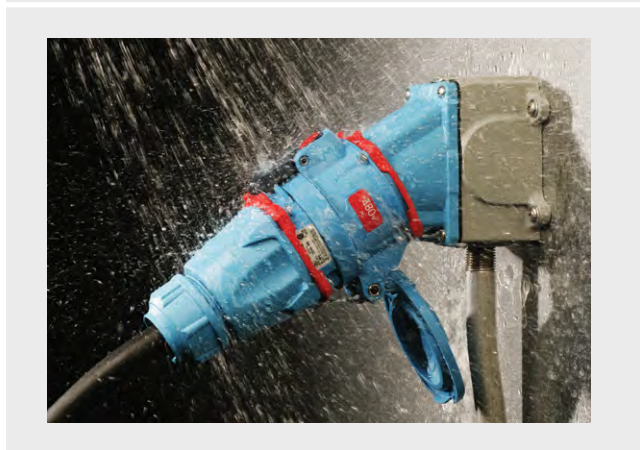

...AND BENEFITS

Spring-Assisted Terminals

The loosening of terminal screws is a common cause for failure on standard plugs and receptacles. MELTRIC provides a more permanent and secure connection with its unique and patented spring-assisted terminal design.

As the terminal screw is tightened against the conductor, the associated pressure expands the split terminal body, causing a spring ring surrounding the terminal to deform into an elliptical shape. The natural tendency for the spring ring to return to its original size and shape ensures that a constant pressure is maintained on the conductor. This allows the terminal to effectively compensate for strand settlement and conductor yield, due to cold flow of the material, and provides superior resistance to vibration, shock and thermal cycling.

Lockout-Tagout Capability

Most MELTRIC plugs and receptacles facilitate compliance with OSHA lockout-tagout requirements. Only a lock or lockout hasp and tag are needed to ensure that the plug is properly locked out and tagged out. Additional mechanisms are not required because the lockout provision is integral to the device – it is always available when you need it. On most models the lockout provision is a simple 5/16" hole in the plug shroud that facilitates the insertion of a typical padlock or lockout hasp which prevents the plug from being inserted into a receptacle.

An optional provision for locking out MELTRIC receptacles is also available. In most cases this is accomplished via a specially machined hole in the receptacle casing which allows insertion of a padlock to secure the receptacle lid in a closed position. This same optional provision can be used to prevent removal of the plug if desired.





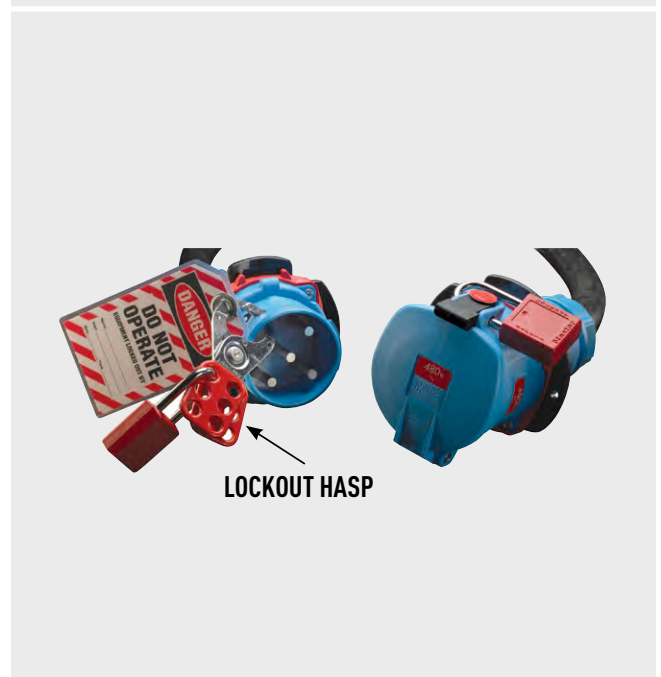
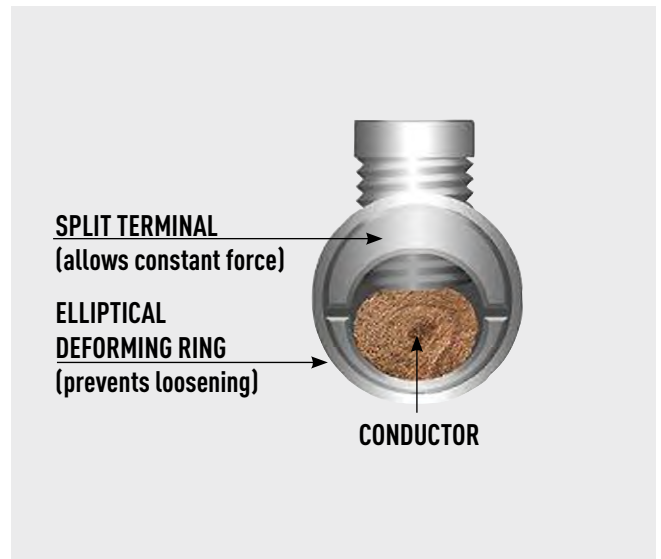

By comparison, in order to lockout most competitive pin and sleeve type plugs, an additional third-party 'lock-out shield' or 'plug cap' is required. These devices can be expensive and are often times lost, broken, or not available when you need them.

Modular Construction

Due to the robust construction of MELTRIC devices, the need to replace worn parts is rare. However, should they be required, parts are readily available and reasonably priced. The modular construction of most MELTRIC devices enables easy replacement of parts in the field.



MELTRIC PRODUCT SUMMARY...

	Model	Amp Rating	Maximum Voltage Rating		Environmental Ratings		Available Casing Materials			Maximum Number of Contacts	
			VAC	VDC	Type	IP	Poly	Metal	SS	Main	Aux.
Switch-Rated	 DSN20	20	600	-	4X	69k	Poly	-	-	3P+N+G	2
	DSN30	30	600	-	4X	69k	Poly	-	-	3P+N+G	2
	DSN60	60	600	-	4X	69k	Poly	-	-	3P+N+G	4
	DSN150	150	600	-	4X	69k	Poly	Metal	-	3P+N+G	6
	DS20	20	600	-	3R	-	Poly	-	-	3P+N+G	2
	DS30	30	600	-	3R	-	Poly	-	-	3P+N+G	4
	 DS60	60	600	-	3R	-	Poly	Metal	-	3P+N+G	4
	DS100C	100	600	-	3R	-	Poly	Metal	-	3P+N+G	4
	DS100	100	600	-	3R	-	Poly	Metal	-	3P+N+G	6
	DS200	200	600	-	3R	-	-	Metal	-	3P+N+G	6
	DB30	30	600	-	-	67	-	Metal	-	3P+N+G	2
	 DB60	60	600	-	-	67	-	Metal	-	3P+N+G	2
DB100	100	600	-	-	67	-	Metal	-	3P+N+G	4	
Multipin	 PN7c	15	600	130	-	66/67*	Poly	Metal	SS	6P+G	-
	PN7c	20	600	130	-	66/67*	Poly	Metal	SS	6P+G	-
	PN12c	5	600	-	-	66/67*	Poly	Metal	SS	11P+G	-
	PN12c	7.5	600	-	-	66/67*	Poly	Metal	SS	11P+G	-
	DSN24c	2	480	130	-	66/67	Poly	-	-	24	-
	DSN24c	7.5	480	130	-	66/67	Poly	-	-	24	-
	DS24c	2	250	130	-	-	-	-	SS	24	-
	 DS24c	7.5	250	130	-	-	-	-	SS	24	-
	DSN37c	2	480	130	-	66/67	Poly	-	-	37	-
	DSN37c	7.5	480	130	-	66/67	Poly	-	-	37	-
	DS37c	2	480	130	-	-	-	-	SS	37	-
	DS37c	7.5	480	130	-	-	-	-	SS	37	-
	 DN9c	20	480	130	-	54/55	-	Metal	-	9	-
	DN20c	20	480	130	-	54/55	-	Metal	-	20	-
	DS7c	30	600	130	-	54/55	Poly	Metal	-	7	3
DR7c	50	600	130	-	54/55	Poly	Metal	-	7	3	

...AND SELECTION GUIDE

Model	Current Interruption Rating*	Horsepower Ratings (see catalog section for other voltages)			Main Contacts Wire Size Capacity		Terminal Type
		240V - 3Ø	480V - 3Ø	600V - 3Ø	Min	Max	
DSN20	Switch-Rated	2 hp	5 hp	5 hp	14 AWG	12 AWG	Screw
DSN30	Switch-Rated	5 hp	10 hp	15 hp	14 AWG	8 AWG	Screw
DSN60	Switch-Rated	7 ½ hp	20 hp	20 hp	12 AWG	4 AWG	Screw
DSN150	Switch-Rated	30 hp	75 hp	75 hp	4 AWG	2/0 AWG	Screw
DS20	Switch-Rated	5 hp	7.5 hp	10 hp	14 AWG	8 AWG	Screw
DS30	Switch-Rated	5 hp	15 hp	15 hp	14 AWG	4 AWG	Screw
DS60	Switch-Rated	10 hp	25 hp	25 hp	10 AWG	2 AWG	Screw
DS100C	Switch-Rated	20 hp	50 hp	50 hp	10 AWG	2 AWG	Screw
DS100	Switch-Rated	10 hp	30 hp	-	4 AWG	2/0 AWG	Screw
DS200	Switch-Rated	40 hp	100 hp	100 hp	4 AWG	4/0 AWG	Screw
DB30	Switch-Rated	7 ½ hp	20 hp	25 hp	14 AWG	8 AWG	Screw
DB60	Switch-Rated	15 hp	30 hp	30 hp	8 AWG	3 AWG	Screw
DB100	Switch-Rated	30 hp	60 hp	60 hp	1/0 AWG	2/0 AWG	Screw
PN7c	Current Interrupting	-	-	-	18 AWG	10 AWG	Screw
PN7c	Non-Current Interrupting	-	-	-	18 AWG	10 AWG	Screw
PN12c	Current Interrupting	-	-	-	18 AWG	14 AWG	Solder/Crimp
PN12c	Non-Current Interrupting	-	-	-	18 AWG	14 AWG	Solder/Crimp
DSN24c	Current Interrupting	-	-	-	18 AWG	14 AWG	Solder/Crimp
DSN24c	Non-Current Interrupting	-	-	-	18 AWG	14 AWG	Solder/Crimp
DS24c	Current Interrupting	-	-	-	18 AWG	14 AWG	Solder/Crimp
DS24c	Non-Current Interrupting	-	-	-	18 AWG	14 AWG	Solder/Crimp
DSN37c	Current Interrupting	-	-	-	18 AWG	14 AWG	Solder/Crimp
DSN37c	Non-Current Interrupting	-	-	-	18 AWG	14 AWG	Solder/Crimp
DS37c	Current Interrupting	-	-	-	18 AWG	14 AWG	Solder/Crimp
DS37c	Non-Current Interrupting	-	-	-	18 AWG	14 AWG	Solder/Crimp
DN9c	Current Interrupting	3 hp	5 hp	-	16 AWG	10 AWG	Screw
DN20c	Current Interrupting	1 hp	3 hp	-	16 AWG	10 AWG	Screw
DS7c	Current Interrupting	-	-	-	14 AWG	8 AWG	Screw
DR7c	Non-Current Interrupting	-	-	-	14 AWG	8 AWG	Screw

* 'Switch-Rated' and 'Current Interrupting' ratings apply to alternating current only.

MELTRIC PART NUMBERING...



First seven (7) digits for a basic inlet or receptacle part number

One (1) to six (6) suffixes for special features

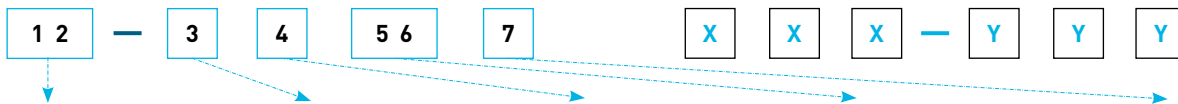

MELTRIC Product Line Type and Casing Material	AMP (A) Rating		Form and Mounting	Voltage Polarization		Phasing
	Position	Voltage		Hz		
PN/PN7c 01 = Blue Poly 09 = Blue Metal	DSN 1 = 20 3 = 30 6 = 60 9 = 150	DXA1 1 = 20	Female 4 = Receptacle	01 = $\frac{220 - 250}{380 - 440}$	50	AC 2 = 2P+G AC 3 = 3P+G AC 5 = 1P+N+G AC 6 = 2P+N+G AC 7 = 3P+N+G AC A ⁺ = 2P AC B ⁺ = 3P AC C ⁺ = 3P+N AC D ⁺ = 1P+N AC G ⁺ = 2P+N AC
PN12c 03 = Blue Poly 07 = Blue Metal	DX 2 = 20* 3 = 30* 6 = 60* 9 = 100*		Male 8 = Inlet	02 = 20/24	60	
PXN12c 06 = Black Metal	DS 1 = 20 3 = 30 6 = 60/100C 9 = 100	6 = 60* 9 = 100*		03 = $\frac{110 - 130}{190 - 230}$	50	
DN 17 = Blue Metal	PF 2 = 200*	3 = 300* 4 = 400* 6 = 600*	DX, DXN37c, PXN12c, SPeX Only	04 = $\frac{255 - 277}{440 - 480}$	60	
DXN 22 = Black Poly	DB 3 = 30* 6 = 60* 9 = 100*	PFQ 3 = 300*	Female 0 = Receptacle on box 3 = Connector 4 = Receptacle	06 = 25/28	50	
DXA1 29 = Black Metal	DR 1 = 30 3 = 50 6 = 100 9 = 150 2 = 250* 4 = 400*	DN 1 = 20*(DN9) 6 = 20*(DN20)	Male 1 = Plug 6 = Inlet on Box	07 = $\frac{110 - 125}{220 - 250}$	60	
DX 26 = Black Metal	PN N = 20 (IP66/ IP67) S = 20 (IP54/ IP55) 2 = 20			08 = 20/24	50	DC 8 ⁺⁺ = 2P+G DC 9 = 2P+G DC Z ⁺ = 2P DC P = 2P+2P+G DC
DS 33 = Blue Poly 35 = Black Poly 36 = Black Metal (HazLoc) 37 = Blue Metal				09 = 480/500	50	* For 50V or less only. ** Includes jumpers.
DXN25/37c 36 = Black Metal				10 = 110/130	DC	
DR 31 = Blue Poly 39 = Blue Metal				11 = $\frac{115 - 127}{200 - 220}$	400	
SPeX 42 = Black Poly				12 = $\frac{115 - 127}{200 - 220}$	200	
CS1000/SP 45 = Black Poly				13 = 40/48	50	
PFQ 47 = Gray Metal				14 = 347/600	60	
PF 49 = Gray Metal				16 = $\frac{120 - 127}{208 - 220}$	60	
DSN 63 = Blue Poly 65 = Black Poly 66 = Black Metal (HazLoc) 69 = Blue Metal				17* = $\frac{110 - 125}{220 - 250}$	60	
DB 89 = Blue Metal				18* = 347/600	60	
				19 = $\frac{380 - 400}{660 - 690}$	50	
				20 = 220/250	DC	
				22 = 577/1000	50	
				23* = $\frac{120 - 127}{208 - 220}$	60	
				24* = $\frac{255 - 277}{440 - 480}$	60	

- Notes:**
- On metal devices, plugs are not painted, receptacles are painted.
 - This is the Keying Standard for MELTRIC products. Suffixes are available to accommodate non-interchangeable devices of the same size at the same voltage. Please ask for more details.

DSN Models and Ratings

Model	Casing Material	Maximum Voltage (VAC)	Amperage Rating	Maximum Number of Contacts		Environmental Rating	Maximum Horsepower Rating	
				Main	Auxiliary		480 VAC	600 VAC
DSN20	Poly	600 VAC	20A	3P+N+G	2 pilots	Type 4X/IP69k	5 hp	5 hp
DSN30	Poly	600 VAC	30A	3P+N+G	2	Type 4X/IP69k	10 hp	15 hp
DSN60	Poly	600 VAC	60A	3P+N+G	4	Type 4X/IP69k	20 hp	20 hp
DSN150	Poly or Metal	600 VC	150A	3P+N+G	6	Type 4X/IP69k	75 hp	75 hp

DS Models and Ratings

Model	Casing Material	Maximum Voltage (VAC)	Amperage Rating	Maximum Number of Contacts		Environmental Rating	Maximum Horsepower Rating	
				Main	Auxiliary		480 VAC	600 VAC
DS20	Poly	600 VAC	20A	3P+N+G	2	Type 3R	7.5 hp	10 hp
DS30	Poly	600 VAC	30A	3P+N+G	4	Type 3R	15 hp	15 hp
DS60	Poly	600 VAC	60A	3P+N+G	4	Type 3R	25 hp	25 hp
DS100C	Poly or Metal	600 VAC	100A	3P+N+G	4	Type 3R	50 hp	50 hp
DS100	Poly or Metal	600 VAC	100A	3P+N+G	6	Type 3R	30 hp	-
DS200	Metal	600 VAC	200A	3P+N+G	6	Type 3R	100 hp	100 hp

DB Models and Ratings

Model	Casing Material	Maximum Voltage (VAC)	Amperage Rating	Maximum Number of Contacts		Environmental Rating	Maximum Horsepower Rating	
				Main	Auxiliary		480 VAC	600 VAC
DB30	Zinc Aluminum	600 VAC	30A	3P+N+G	2	IP67	20 hp	25 hp
DB60	Zinc Aluminum	600 VAC	60A	3P+N+G	2	IP67	30 hp	30 hp
DB100	Zinc Aluminum	600 VAC	100A	3P+N+G	4	IP67	60 hp	60 hp

DB Switch-Rated plug and receptacle

NOTE: The DB product line is being phased out in Q3 2019. Please consider alternative DSN and DS models.

Main Advantages

- ▶ Switch & Hp rated
- ▶ 100 kA short circuit rated*
- ▶ IP67 environmental ratings
- ▶ Up to 4 auxiliary contacts
- ▶ Durable metal construction

* See note under General Ratings on the next page.



Highlighted Advantage

! Simplify Compliance to NFPA 70E & CSA Z462 see pgs 18-19 for more information



- | | | | |
|------------------------|-------|---------------|-------|
| ▶ Features and Ratings | p. 57 | ▶ Spare parts | p. 66 |
| ▶ DB30 | p. 60 | ▶ Dimensions | p. 68 |
| ▶ DB60 | p. 62 | | |
| ▶ DB100 | p. 64 | | |

PRODUCT FEATURES

DECONTACTOR™ Technology

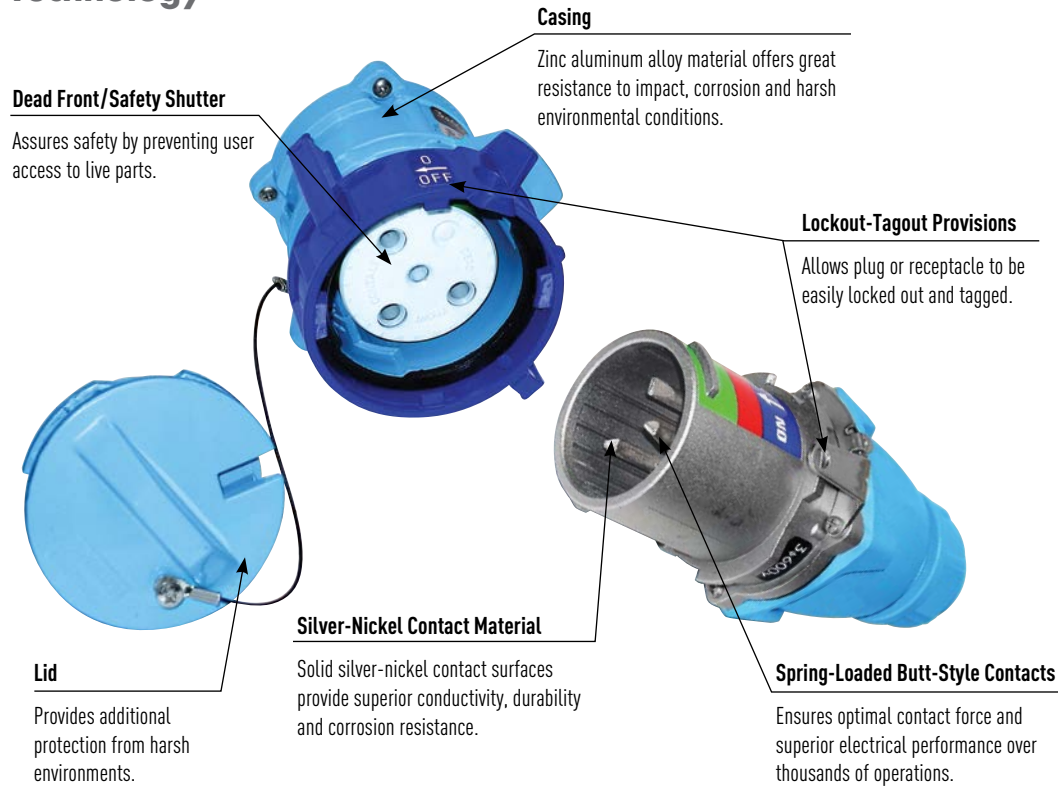

General Ratings

Amperage	30 to 100A
Voltage	600 VAC
Frequency	50-400 Hz
Horsepower	2 to 60 hp
Short-Circuit (Make & Withstand)	100kA*
Environmental	IP67
Temperature	min -40°F/max 140°F

* Testing was performed with RK1 current limiting fuses sized at 400% of the highest full load motor ampacity associated with the devices horsepower ratings, except for the DB100, which was tested with 250A fuses.

Highlighted Feature

Typical Device Labels

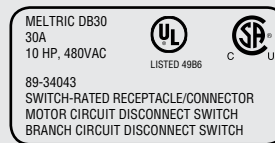

Meltric DB Series Switch-Rated devices are UL & CSA rated for "motor circuit" and "branch circuit" disconnect switching – up to 60 hp and up to 100A.

Listings

Category	UL	CSA	IEC
Plugs and Receptacles	UL 1682	C22.2 No. 182.1	60309-1
Branch Circuit Disconnect Switching (AC only)	UL Subject 2682 (Performance tests from UL 98)	UL Subject 2682	60947-3, AC22, AC23
Motor Circuit Disconnect Switching (AC only)	UL Subject 2682 (Performance tests from UL 98)	UL Subject 2682	60947-3, AC22, AC23

CE ratings available upon request.

Operating Instructions



When the plug and receptacle are latched together, the circuit is connected.



Turning the receptacle ring counterclockwise releases the plug and rapidly opens the circuit. The plug is ejected to its rest position.



From the rest position the 'dead' plug can be withdrawn by rotating it counterclockwise. The receptacle can be made watertight up to IP67 by replacing the lid and turning the locking ring fully clockwise.



To reconnect, insert plug and twist. Pushing the plug fully home safely makes the circuit. The plug is held in the 'on' position by a locking ring. IP67 protection is enabled by fully rotating the locking ring in the clockwise direction.

PRODUCT FEATURES

Spring-Loaded Operating Mechanism

DB Series Switch-Rated plugs and receptacles use an internal spring-loaded operating mechanism to open and close the contacts at high speed, independent of the manual motion of the user.

Load-Making

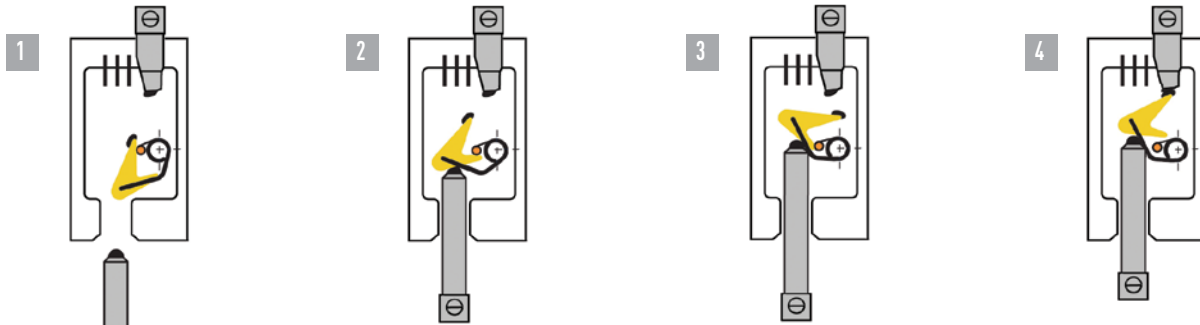

1. As the plug is first inserted into the receptacle, the contact travels toward the operating mechanism. Only the receptacle contact (shown at the top of the drawing) is live.
2. As the plug contact is inserted further, it engages a mobile intermediate contact on the operating mechanism, which it begins to move around a stop. This motion also begins to wind the operating spring.
3. As the plug is inserted further, to the almost completely engaged position, the operating spring becomes fully loaded and the mobile contact rotates into a position where any further insertion motion will release it from the stop.
4. As the last small insertion motion is made, the mobile contact clears the stop and releases the energy in the spring. This instantly drives the mobile contact into engagement with the receptacle contact and completes the electrical connection.

Load-Breaking

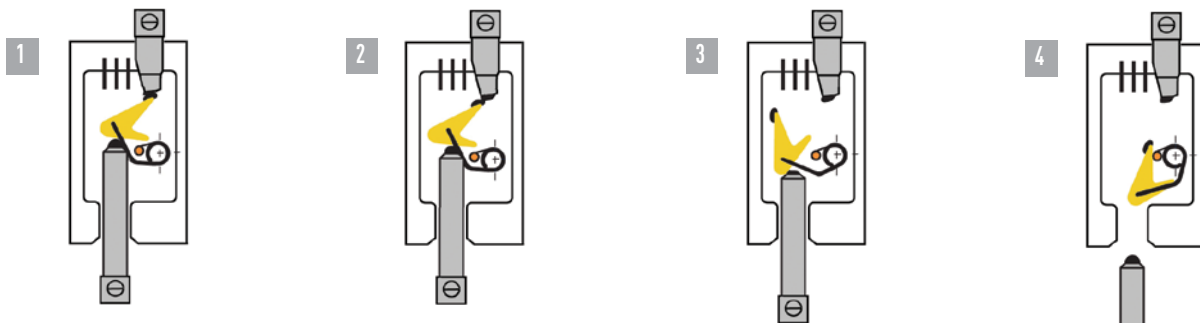

1. When the contacts are engaged, the operating spring is still almost fully charged. This maintains contact pressure and provides energy for the breaking operation.
2. In order to break the circuit, the plug retaining ring is turned to the 'off' position. This releases the plug, which in turn releases the mobile contact and the spring energy in the operating mechanism.
3. The spring energy instantly drives the mobile contact away from the live receptacle contact. It follows a different path than on making and is moved along an arc chute.
4. The mobile contact returns to its initial position, preparing the device to be used again.

Two Stage Contact System

The operation of the DB's contacts was specifically designed to ensure that load-breaking and load-carrying are performed in separate locations on the contacts.

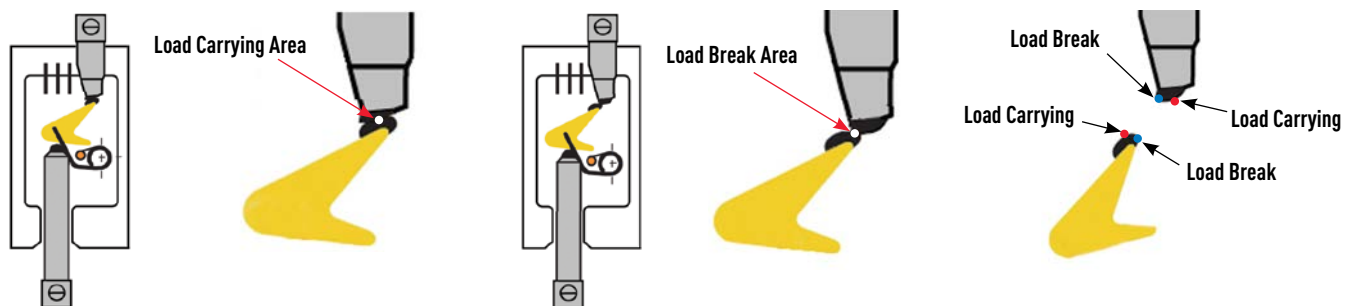

This is accomplished with the motion of the mobile contact relative to the receptacle contact. The opening of the contacts begins with a wiping action that moves the contact area toward the edges of the contacts, where load-breaking occurs. This allows numerous overload-breaking operations without deteriorating the main contact surfaces or the continuity of the connection.

Arc-Extinguishing System

For higher currents, or when significant overloads are involved, additional provision is desirable to handle the arcing that occurs during load-breaking. MELTRIC accomplishes this on its DB Series with a series of magnetic V-shaped blades, which create an arc chute.

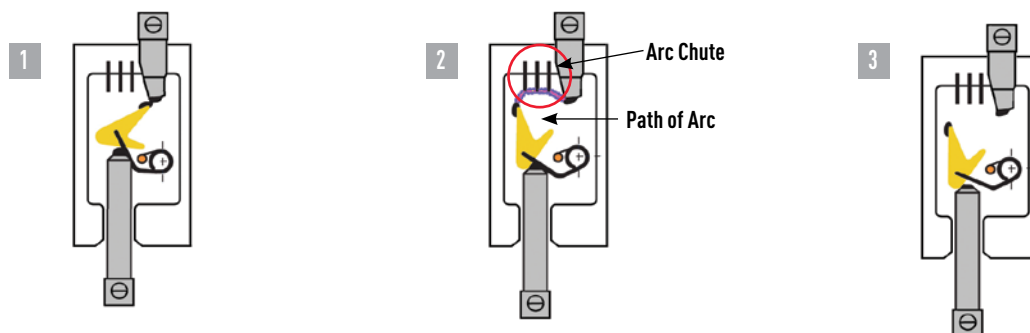

As the contacts open, the mobile intermediate contact moves along the arc chute. The arc is transferred to the magnetic "V" shaped blades, which splits and destabilizes it. This helps to cool and quickly extinguish the arc, minimizing any potential damage to the contacts. Together with the spring operator, two stage contact system and silver-nickel butt-style contacts, this feature allows the DB series to easily and safely break high horsepower inductive loads and significant overloads.

DB30 Switch-Rated Plugs & Receptacles – 30A

UL/CSA Ratings

- **Max Amperage & Voltage**
30A, 600 VAC
- **Switch-Rating (AC Only)**
Branch Circuit & Motor Circuit Disconnect Switching
- **Horsepower Ratings**

120V	1Ø	2 hp
240V	1Ø	3 hp
208V	3Ø	7 1/2 hp
240V	3Ø	7 1/2 hp
480V	3Ø	20 hp
600V	3Ø	25 hp
- **Short Circuit Rating**
100kA Close & Withstand
Testing was performed with RK1 current limiting fuses sized at 400% of the highest full load motor ampacity associated with the devices hp rating.
- **Environmental Ratings**
IP67
- **Temperature Range**
Min -40°F/Max 140°F
See pg 271 for temps below -15°F.
- **Wiring Capacity**
Min 14 AWG Max 8 AWG
Aux Contacts - Max 14 AWG
- **Certifications**
UL 2682, CSA 182.1

NOTE: The DB product line is being phased out in Q3 2019. Please consider alternative DSN and DS models.

Receptacle (female)



Inlet (male)



! Don't forget to add installation accessories to your order

North American UL/CSA Configurations

Voltage	Polarity	Part # Metal	Part # Metal
120V	1P+N+G	89-34165	89-38165
120 208V	3P+N+G	89-34167	89-38167
125V	1P+N+G	89-34075	89-38075
125 250V	2P+N+G	89-34076	89-38076
208V	2P+G	89-34162	89-38162
208V	3P+G	89-34163	89-38163
250V	2P+G	89-34072	89-38072
250V	3P+G	89-34073	89-38073
277V	1P+N+G	89-34045	89-38045
277 480V	3P+N+G	89-34047	89-38047
347 600V	3P+N+G	89-34147	89-38147
480V	2P+G	89-34042	89-38042
480V	3P+G	89-34043	89-38043
600V	2P+G	89-34142	89-38142
600V	3P+G	89-34143	89-38143

For international configurations and ratings (IEC, CE) visit meltric.com/international-catalog or contact customer service at 800.433.7642.

Main Options



Auxiliary/Pilot Contacts

Receptacle Options

Suffix

Inlet Options

Suffix

With 2 Auxiliary/Pilot Contacts

Recept # - 172*

With 2 Auxiliary/Pilot Contacts

Inlet # - 172*

Notes: * Auxiliary/Pilot Contacts are not available on DB devices with 1P+N+G, 2P+N+G or 3P+N+G polarity.





! See pages 248-257 for detailed information on these options



Order Example: 480V DB30 + 2 auxiliary contacts
DB30 Metal inlet 3P+G = 89-38043-172

INSTALLATION ACCESSORIES – SIZE 3

Unless indicated otherwise, accessories can be used with either poly or metal plugs and receptacles.

HANDLES

HANDLE w/NPT	Part # Poly	Part # Metal
 1/2"	513P0N05	593P0N05
 3/4"	513P0N07	593P0N07
 1"	513P0N10	593P0N10
 1 1/4"	513P0N12	593P0N12
For metal devices only 1 1/2"	-	593P0N15

HANDLE w/CORD GRIP	Cable Range	Poly	Metal
	.625 - .750"	713P0CP4	793P0CS4
	.770 - .875"	713P0DP2	793P0DS1
	.875 - 1.000"	713P0DP3	793P0DS3

NYLON HANDLE w/Cable Range		
	.390 - 1.18"	513P0D30





POLY HANDLE w/CLAMP & BUSHING w/Cable Range		
	.750 - .875"	713P0S14
	.875 - 1.000"	713P0S16
	1.000 - 1.125"	713P0S18
	1.125 - 1.250"	713P0S20
	1.250 - 1.375"	713P0S22

For available cord grips, see pg 178.

Cable Range	NPT	Cable Range	NPT
.312 - .625	1/2"	.875 - 1.375"	1 1/4"
.438 - .812	3/4"	.890 - 1.812"	1 1/2"
.660 - 1.000	1"		

NPT sizes are determined by the cable diameter and third party cord grip.

ANGLES

METAL ANGLE		
	0°	593M0
	30°	593M3
	FS/FD Box 30°	793M3FS
	70°	593M7

* Base measures approximately 4.2" x 2.7". Due to the variation in sizes of FS boxes, please verify that your FS box matches our dimensions, if not call Customer Service for other solutions.

BOXES

METAL BOX w/NPT			
	0°	1/2"	7T1F0N05
	0°	3/4"	7T1F0N07
	0°	1"	7T1F0N10
	0°	1 1/4"	7T1F0N12

METAL BOX WITH METAL ANGLE w/NPT			
	70°	1/2"	793C7N05
	70°	3/4"	793C7N07
	70°	1"	793C7N10
* 27.7 in ³	70°	1 1/4"	793C7N12

* Interior volume with receptacle installed.

NPT on top or bottom (if rotated). For other NPT configurations, contact customer service.

MISCELLANEOUS ACCESSORIES

PROTECTIVE CAP		
	89-3A126	For Male Devices Only.

CORD GRIP with or w/o MESH	
	see pgs 178

EASY RETROFIT ADAPTER PLATES	
	see pg 175 Mount to existing boxes.

DB60 Switch-Rated Plugs & Receptacles – 60A

UL/CSA Ratings

- **Max Amperage & Voltage**
60A, 600 VAC
- **Switch-Rating (AC Only)**
Branch Circuit & Motor Circuit Disconnect Switching
- **Horsepower Ratings**

120V	1Ø	3 hp
240V	1Ø	7.5 hp
208V	3Ø	15 hp
240V	3Ø	15 hp
480V	3Ø	30 hp
600V	3Ø	30 hp
- **Short Circuit Rating**
100kA Close & Withstand
Testing was performed with RK1 current limiting fuses sized at 400% of the highest full load motor ampacity associated with the devices hp rating.
- **Environmental Ratings**
IP67
- **Temperature Range**
Min -40°F/Max 140°F
See pg 271 for temps below -15°F.
- **Wiring Capacity**
Min 8 AWG Max 3 AWG
Aux Contacts - Max 14 AWG
- **Certifications**
UL 2682, CSA 182.1

NOTE: The DB product line is being phased out in Q3 2019. Please consider alternative DSN and DS models.

Receptacle (female)



Inlet (male)



! Don't forget to add installation accessories to your order

North American UL/CSA Configurations

Voltage	Polarity	Part # Metal	Part # Metal
120V	1P+N+G	89-64165	89-68165
120 208V	3P+N+G	89-64167	89-68167
125V	1P+N+G	89-64075	89-68075
125 250V	2P+N+G	89-64076	89-68076
208V	2P+G	89-64162	89-68162
208V	3P+G	89-64163	89-68163
250V	2P+G	89-64072	89-68072
250V	3P+G	89-64073	89-68073
277V	1P+N+G	89-64045	89-68045
277 480V	3P+N+G	89-64047	89-68047
347 600V	3P+N+G	89-64147	89-68147
480V	2P+G	89-64042	89-68042
480V	3P+G	89-64043	89-68043
600V	2P+G	89-64142	89-68142
600V	3P+G	89-64143	89-68143

For international configurations and ratings (IEC, CE) visit meltric.com/international-catalog or contact customer service at 800.433.7642.

Main Options



Auxiliary/Pilot Contacts

Receptacle Options

Suffix

Inlet Options

Suffix

With 2 Auxiliary/Pilot Contacts

Recept # - 172*

With 2 Auxiliary/Pilot Contacts

Inlet # - 172*

Notes: * Auxiliary/Pilot Contacts are not available on DB devices with 1P+N+G, 2P+N+G or 3P+N+G polarity.





! See pages 248-257 for detailed information on these options



Order Example: 480V DB60 + 2 auxiliary contacts
DB60 Metal inlet 3P+G = 89-68043-172

INSTALLATION ACCESSORIES – SIZE 4

Unless indicated otherwise, accessories can be used with either poly or metal plugs and receptacles.

HANDLES

HANDLE w/NPT	Part # Poly	Part # Metal
 1/2"	514P0N05	594P0N05
 3/4"	514P0N07	594P0N07
 1"	514P0N10	594P0N10
 1 1/4"	514P0N12	594P0N12
For metal devices only 1 1/2"	514P0N15	594P0N15





HANDLE w/CORD GRIP	Cable Range	Poly	Metal
	.750-.875"	714P0DP2	794P0DS1
	.875-1.000"	714P0DP3	794P0DS3
	1.000-1.125"	714P0EP2	794P0ES2

For metal devices only

NYLON HANDLE w/Cable Range

 .51 - 1.38"	514P0D35
---	----------

POLY HANDLE w/CLAMP & BUSHING w/Cable Range

 1.250 - 1.375"	714P0S22
 1.438 - 1.562"	714P0S25
 1.562 - 1.688"	714P0S27
 1.688 - 1.812"	714P0S29





For available cord grips, see pg 178.

i



Cable Range	NPT	Cable Range	NPT
.312 - .625	1/2"	.875 - 1.375"	1 1/4"
.438 - .812	3/4"	.890 - 1.812"	1 1/2"
.660 - 1.000	1"		



NPT sizes are determined by the cable diameter and third party cord grip.

ANGLES

METAL ANGLE	Angle	Part #	Notes
	0°	594M0	
	30°	594M3	
	30°	794M3L	
	Oversized 30°	794M3	Mounts on oversize box only. Order with 7T4F0Nxx box. See page 64.
	70°	594M7	

BOXES

METAL BOX w/NPT	Angle	Width	Part #
	0°	1"	7T4F0N10
	0°	1 1/4"	7T4F0N12
	0°	1 1/2"	7T4F0N15
	0°	2"	7T4F0N20

METAL BOX WITH METAL ANGLE w/NPT	Angle	Width	Part #
	70°	1"	794C7N10
	70°	1 1/4"	794C7N12
	70°	1 1/2"	794C7N15
* 91.0 in ³	70°	2"	794C7N20

* Interior volume with receptacle installed.

NPT on top or bottom (if rotated). For other NPT configurations, contact customer service.

MISCELLANEOUS ACCESSORIES

PROTECTIVE CAP	Part #	Notes
	89-6A126	For Male Devices Only.

CORD GRIP with or w/o MESH	Notes
	see pgs 178

EASY RETROFIT ADAPTER PLATES	Notes
	see pg 175 Mount to existing boxes.

DB100 Switch-Rated Plugs & Receptacles – 100A

UL/CSA Ratings

- **Max Amperage & Voltage**
100A, 600 VAC
- **Switch-Rating (AC Only)**
Branch Circuit & Motor Circuit Disconnect Switching
- **Horsepower Ratings**

120V	1Ø	7 1/2 hp
240V	1Ø	15 hp
208V	3Ø	30 hp
240V	3Ø	30 hp
480V	3Ø	60 hp
600V	3Ø	60 hp
- **Short Circuit Rating**
100kA Close & Withstand
Testing was performed with 250A RK1 fuses, so the 100kA rating applies up to 60 hp @ 600, 40 hp @ 480V and 20 hp @ 240V and 208V.
- **Environmental Ratings**
IP67
- **Temperature Range**
Min -40°F/Max 140°F
See pg 271 for temps below -15°F.
- **Wiring Capacity**
Min 1/0- AWG Max 2/0 AWG
Aux Contacts - Max 14 AWG
+ Smaller conductors can be retained in the terminal, but may result in a temperature rise greater than the 30° max allowed in UL & CSA standards.
- **Certifications**
UL 2682, CSA 182.1

NOTE: The DB product line is being phased out in Q3 2019. Please consider alternative DSN and DS models.

Receptacle (female)



Inlet (male)



! Don't forget to add installation accessories to your order

North American UL/CSA Configurations

Voltage	Polarity	Part # Metal	Part # Metal
120V	1P+N+G	89-94165	89-98165
120 208V	3P+N+G	89-94167	89-98167
125V	1P+N+G	89-94075	89-98075
125 250V	2P+N+G	89-94076	89-98076
208V	2P+G	89-94162	89-98162
208V	3P+G	89-94163	89-98163
250V	2P+G	89-94072	89-98072
250V	3P+G	89-94073	89-98073
277V	1P+N+G	89-94045	89-98045
277 480V	3P+N+G	89-94047	89-98047
347 600V	3P+N+G	89-94147	89-98147
480V	2P+G	89-94042	89-98042
480V	3P+G	89-94043	89-98043
600V	2P+G	89-94142	89-98142
600V	3P+G	89-94143	89-98143

For international configurations and ratings (IEC,CE) visit meltric.com/international-catalog or contact customer service at 800.433.7642.

Main Options



Auxiliary/Pilot Contacts

Receptacle Options

Suffix

Inlet Options

Suffix

With 4 Auxiliary/Pilot Contacts

Recept # - 174**

With 4 Auxiliary/Pilot Contacts

Inlet # - 174**

Notes: * DB100 devices with auxiliary/pilot contacts are not UL/CSA listed.

** Auxiliary/Pilot Contacts are not available on DB devices with 1P+N+G, 2P+N+G or 3P+N+G polarity.

! See pages 248-257 for detailed information on these options





Order Example: 480V DB100 + 4 auxiliary contacts





DB100 Metal inlet 3P+G = 89-98043-174



INSTALLATION ACCESSORIES – SIZE 5

Unless indicated otherwise, accessories can be used with either poly or metal plugs and receptacles.

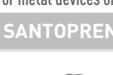
HANDLES

HANDLE w/NPT	Part # Poly	Part # Metal
 3/4"	515P0N07	595P0N07
 1"	515P0N10	595P0N10
 1 1/4"	515P0N12	595P0N12
 1 1/2"	515P0N15	595P0N15
For metal devices only 2"	515P0N20	595P0N20

HANDLE w/CORD GRIP	Cable Range	Poly	Metal
	1.270 - 1.470"	715P0EP3	-
	1.250 - 1.375"	-	795P0ES4
	1.438 - 1.562"	-	795P0FS2
	1.562 - 1.688"	-	795P0FS3
For metal devices only	1.520 - 1.860"	715P0GP2	-

SANTOPRENE HANDLE w/Cable Range		
	.70 - 1.000"	555P0D25
	1.00 - 1.375"	555P0D35
IP 66/67	1.375 - 1.750"	555P0D45

POLY HANDLE w/CLAMP & BUSHING w/Cable Range	
	1.250 - 1.375" 715P0S22
	1.438 - 1.562" 715P0S25
	1.562 - 1.688" 715P0S27
	1.688 - 1.812" 715P0S29

For available cord grips, see pg 178.

BOXES

METAL BOX w/NPT			
	0°	1 1/4"	7T5F0N12
	0°	1 1/2"	7T5F0N15
	0°	2"	7T5F0N20

METAL BOX WITH METAL ANGLE w/NPT			
	70°	1 1/4"	795C7N12
	70°	1 1/2"	795C7N15
	70°	2"	795C7N20

* 175.0 in³

* Interior volume with receptacle installed.





NPT on top or bottom (if rotated). For other NPT configurations, contact customer service.

i

Cable Range	NPT	Cable Range	NPT
.438 - .812	3/4"	.890 - 1.812"	1 1/2"
.660 - 1.000	1"	1.190 - 2.438"	2"
.875 - 1.375"	1 1/4"		

NPT sizes are determined by the cable diameter and third party cord grip.

ANGLES

METAL ANGLE		
	0°	595M0
	30°	595M3
	30°	795M3
		Mounts on oversize box only. Order with 7T5F0Nxx box. See page 64.
	70°	595M7

MISCELLANEOUS ACCESSORIES

PROTECTIVE CAP	
	89-9A126 For Male Devices Only.

CORD GRIP with or w/o MESH	
	see pgs 175

EASY RETROFIT ADAPTER PLATES	
	see pg 175 Mount to existing boxes.

DB SPARE PARTS Male Configuration

NOTE: The DB product line is being phased out in Q3 2019. Please consider alternative DSN and DS models.

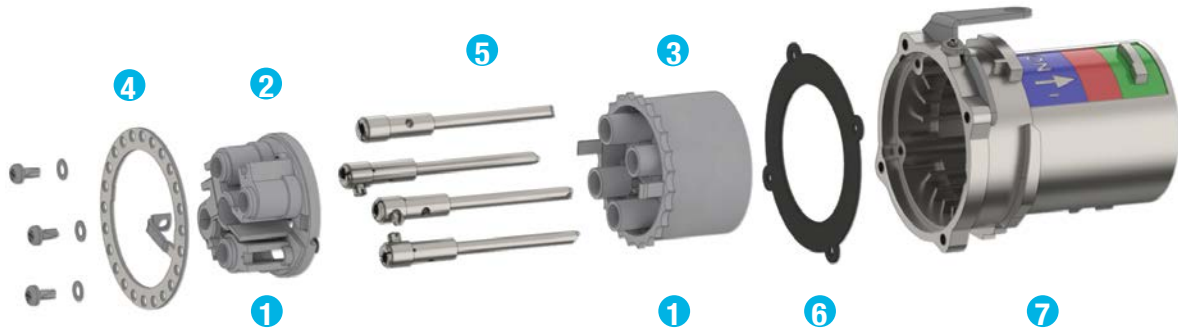

	DB30 METAL	DB60 METAL	DB100 METAL
1 Plug Interior with Pilot Contact Assembly	89-3A010-172*	89-6A010-172*	89-9A010-174*
1 Plug Interior without Pilot Contact Assembly	89-3A010	89-6A010	89-9A010
2 Interior Bottom***	89-3A010-B	89-6A010-B	89-9A010-B
3 Interior Top for Pilot Contact Assembly	89-3A010-T-172*	89-6A010-T-172*	89-9A010-T-174*
3 Interior Top w/o Pilot Contact Assembly Holes	89-3A010-T*	89-6A010-T*	89-9A010-T*
4 Metal Locking Ring/Ground Ring	89-3A523	89-6A523	89-9A523
5 Ground Contact	89-3A019	89-6A019	89-9A019
5 Phase or Neutral Contact	89-3A011	89-6A011	89-9A011
5 Pilot (2 Contacts) Assembly (not shown)	89-3A219-172	89-6A219-172	-
5 Pilot (4 Contacts) Assembly (not shown)	-	-	89-9A219-174
6 Device Gasket	89-3A026	89-6A026	89-9A026
7 Plug Metal Casing	89-3A014**	89-6A014**	89-9A014**

* Voltage and phasing positions must be specified (5th, 6th & 7th digit of Part #) to duplicate your shutter and alignment notches.

** For appropriate labeling on a device, please specify voltage, phasing, and product type.

DB SPARE PARTS Female Configuration

NOTE: The DB product line is being phased out in Q3 2019. Please consider alternative DSN and DS models.

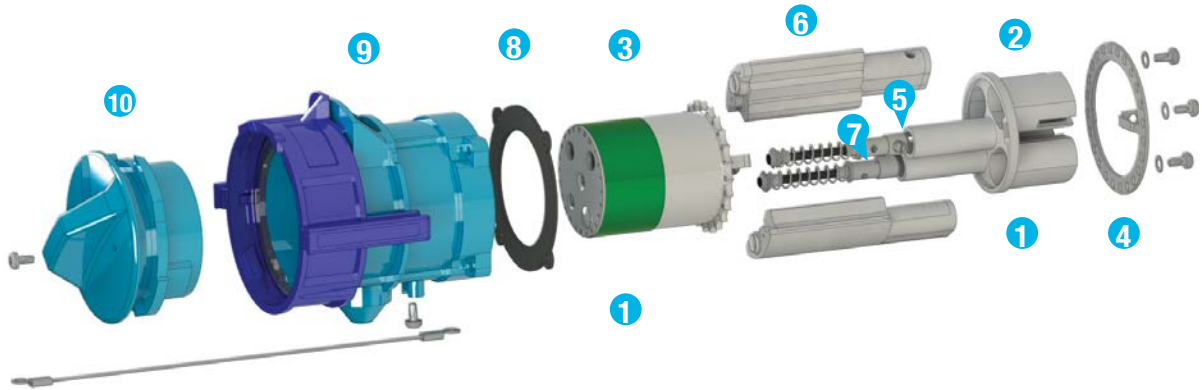

	DB30 METAL	DB60 METAL	DB100 METAL
1 Receptacle Interior w/Pilot Contact Assembly	89-3A020-172*	89-6A020-172*	89-9A020-174*
1 Receptacle Interior w/o Pilot Contact Assembly	89-3A020*	89-6A020*	89-9A020*
2 Interior Bottom***	89-3A020-B	89-6A020-B	89-9A020-B
3 Interior Top for Pilot Contact Assembly	89-3A020-T-172*	89-6A020-T-172*	89-9A020-T-174*
3 Interior Top for Pilot Contact Assembly Holes	89-3A020-T*	89-6A020-T*	89-9A020-T*
4 Metal Locking Ring/Ground Ring	89-3A523	89-6A523	89-9A523
5 Ground Contact	89-3A029	89-6A029	89-9A029
6 Phase Contact	89-3A021	89-6A021	89-9A021
7 Neutral Contact	89-3A021N	89-6A021N	89-9A021N
7 Pilot (2 Contacts) Assembly (not shown)	89-3A229-172	89-6A229-1726	-
7 Pilot (4 Contacts) Assembly (not shown)	-	-	89-9A229-174
8 Device Gasket	89-3A026	89-6A026	89-9A026
9 Receptacle Metal Casing	89-3A024**	89-6A024**	89-9A024**
10 Protective Cap with Nylon Cord	89-3A925**	89-6A925**	89-9A925**

* Voltage and phasing positions must be specified (5th, 6th & 7th digit of Part #) to duplicate your shutter and alignment notches.

** For appropriate labeling on a device, please specify voltage, phasing, and product type.

DB DIMENSIONS Inlet – Provided in inches

Dimensions are for reference only and may change depending on accessories used. For precise dimensions contact MELTRIC Engineering.

NOTE: The DB product line is being phased out in Q3 2019. Please consider alternative DSN and DS models.

Inlet

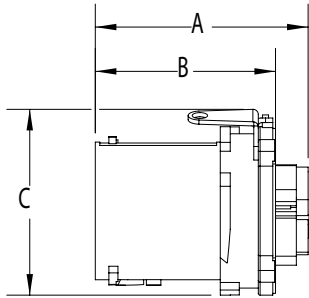

Plug

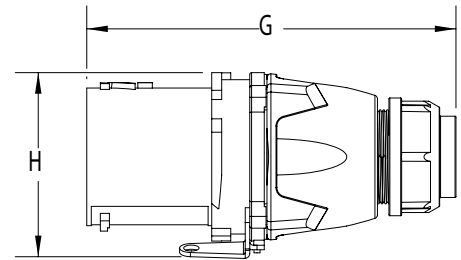
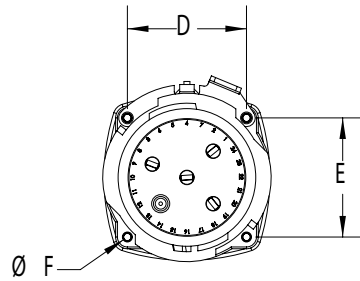

PRODUCT	A	B	C	D	E	øF	G	H
DB30	4.42	3.75	3.11	2.19	2.19	0.18	7.89	3.15
DB60	4.63	3.92	4.04	2.59	2.59	0.22	8.03	4
DB100	6.28	4.63	4.33	3.2	3.2	0.22	9.78	4.46

Receptacle

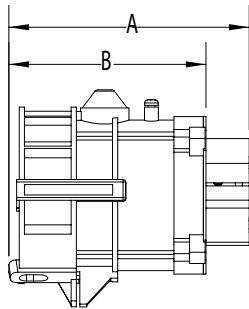

Connector

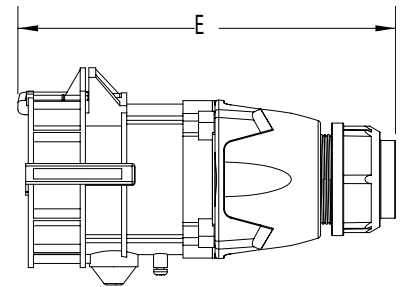
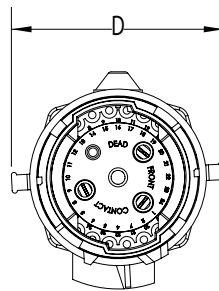

PRODUCT	A	B	C	D	E
DB30	6.17	5.16	3.54	4.36	8.02
DB60	6.52	5.46	4.02	4.84	8.59
DB100	8.52	6.77	4.94	5.75	10.67



NOTE: The DB product line is being phased out in Q3 2019. Please consider alternative DSN and DS models.

**Junction Box /70° Angle/
Receptacle/with Plug**

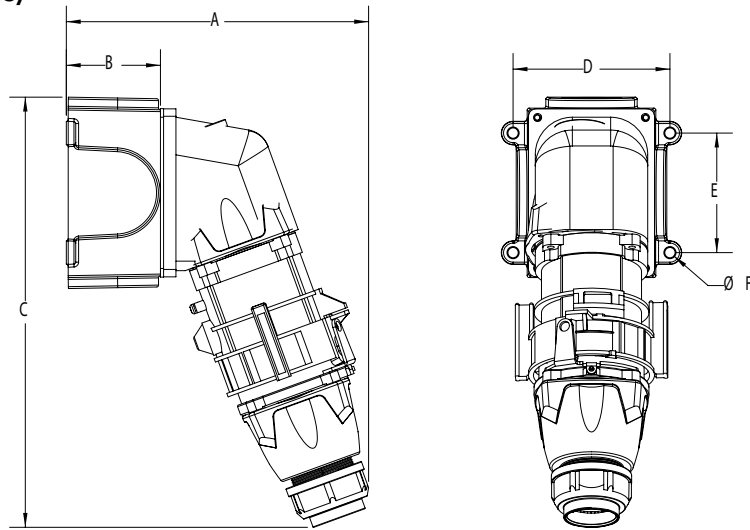

PRODUCT	A	B	C	D	E	F
DB30	8.54	2.27	11.65	4.19	2.75	0.27
DB60	9.63	3	13.71	5	3.81	0.33
DB100	12.24	3.77	17.6	6.75	4.25	0.31

Connector/Plug

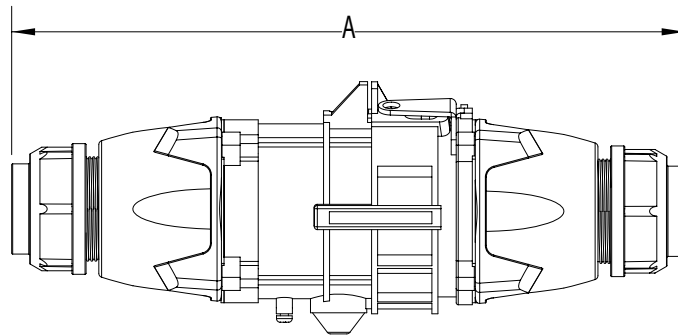

PRODUCT	A
DB30	13.01
DB60	13.19
DB100	16.65

